

# DELICE MODEL - REFRIGERATED MERCHANDISER WITH SQUARE GLASS

With ventilated refrigeration system



### Applications:

Deli, sandwiches, prepared foods, cheese, pastries and fresh pasta.

### Features:

- Vertical showcase (with downtilting glass) with a modern look ensuring maximum visibility.
- Sturdy glass construction on 4 sides and on top.
- Includes 2 adjustable glass shelves and bottom.
- T8 Lighting on canopy and shelves.
- Stainless steel display surface.
- Rear sliding doors.
- Ventilated refrigeration system.
- Self-contained compressor.
- Electronic temperature control and automatic defrost with evaporation pan.
- Dimensions: 33" depth x 51" height.
- Available lengths 3', 4', 6', 8' and 12'.
- Operating temperature: 34°F to 45°F (1°C to 7°C).

### Options:

- Remote condensing unit.
- Available non refrigerated (Dry Case).
- Customizable front.
- LED lighting on canopy and shelves.

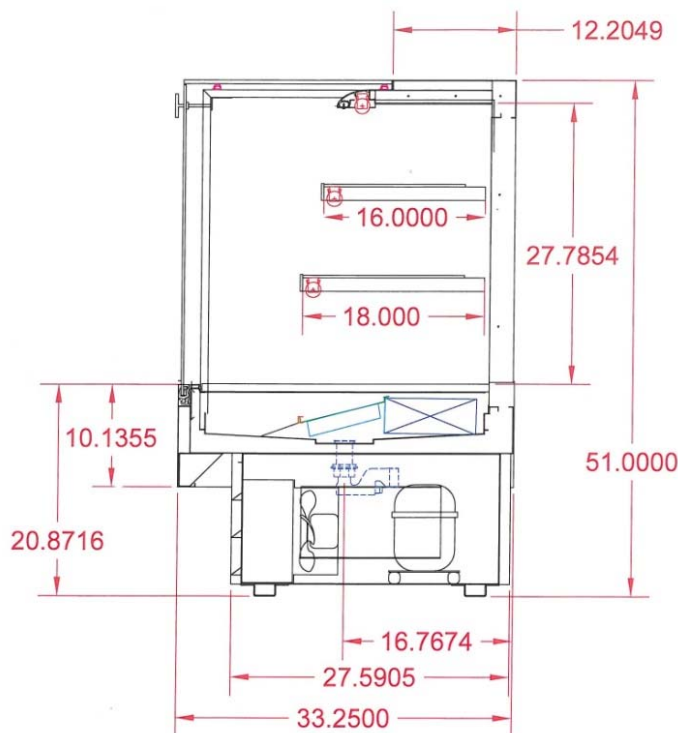

Side view

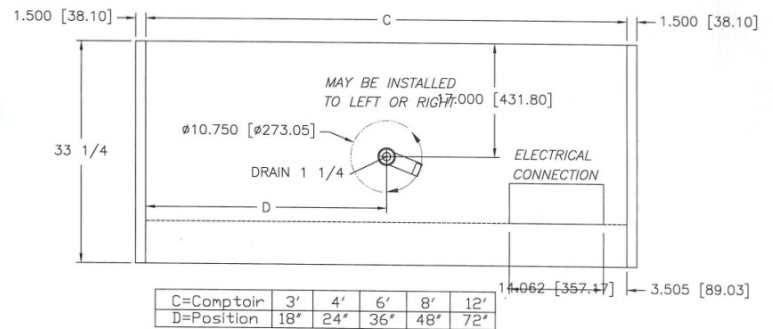

Top view (showing drain and electrical)

Merchandisers are designed for in-store use where temperature and humidity do not exceed 75°F and 55% RH.

Specifications subject to change without notice. Rev. 27-04-2022