

Section 1 – Meat/Viandes fraîches

M-13

Modèle EM6A Model

Multi-Deck Fresh Meat Merchandisers – Std Base
Présentoirs pour viandes fraîches à niveaux multiples – Base std

Cross-section / Vue de coupe

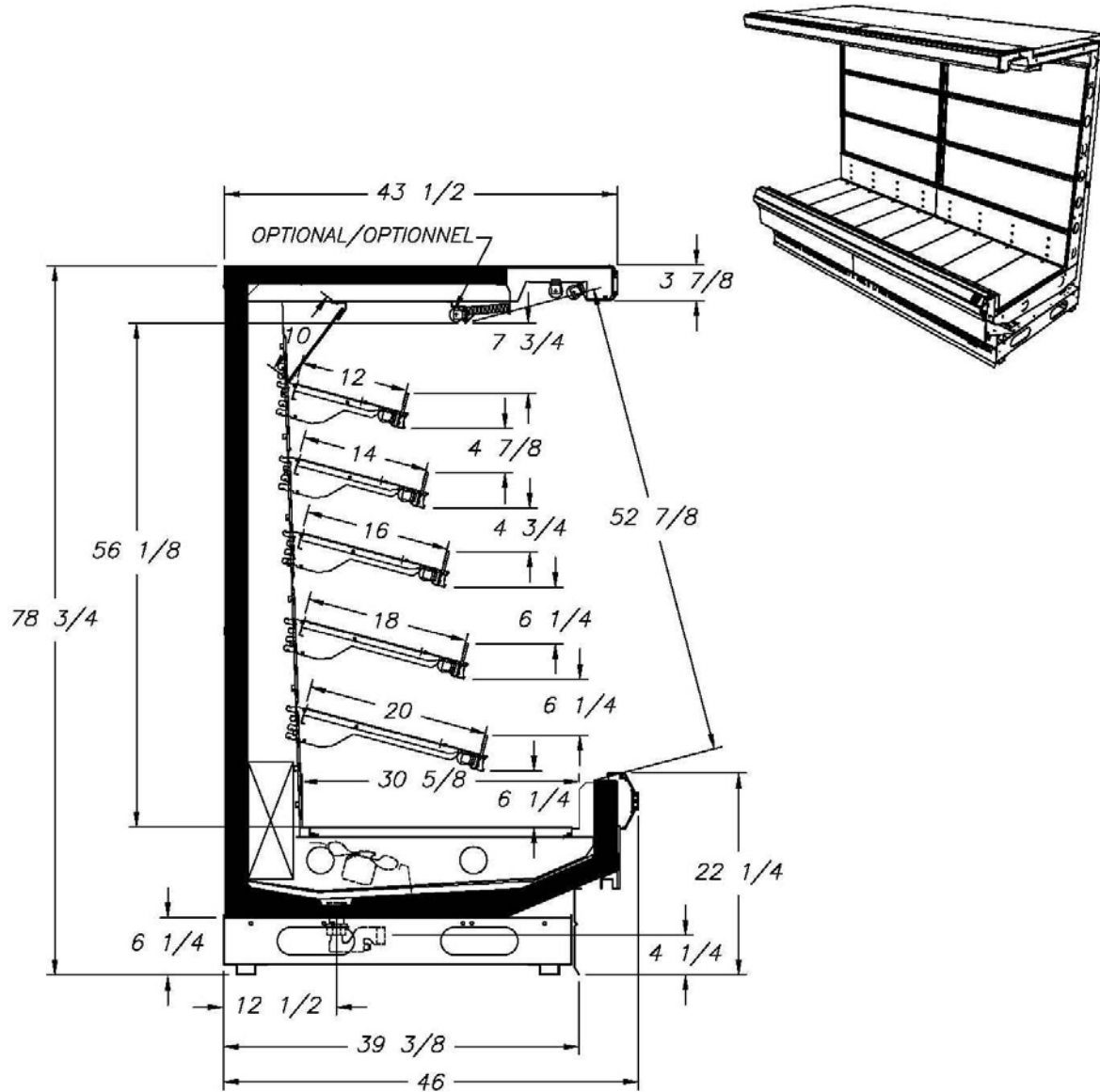

EM6A



Section 1 – Meat/Viandes fraîches

M-13

Modèle EM6A Model

Multi-Deck Fresh Meat Merchandisers – Std Base
Présentoirs pour viandes fraîches à niveaux multiples – Base std

Top View / Vue de plan

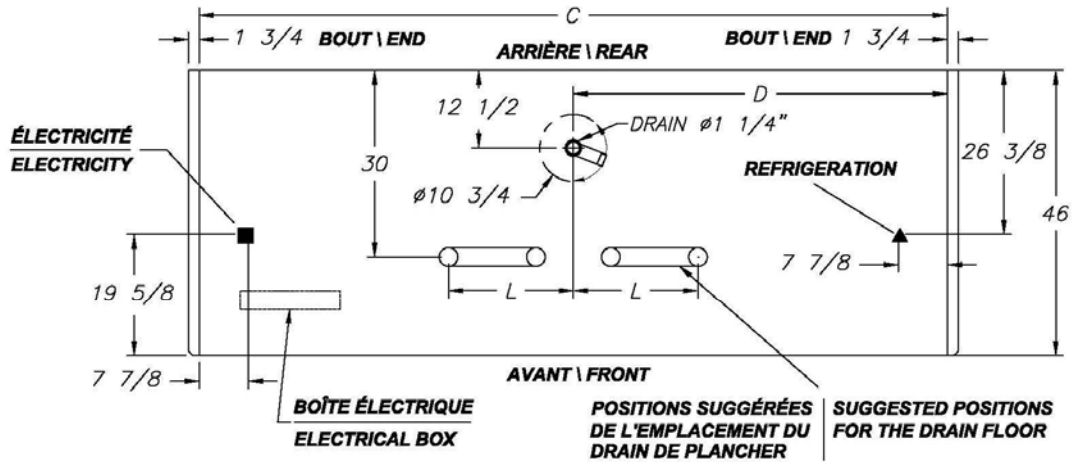

C=Comptoir	48"	72"	96"	120"	144"
D=Position	24"	32"	44"	60"	72"
L=Longueur	16"	20"	24"	20"	20"

45° EXTERIOR CORNER
45° COIN EXTERIEUR
DRAIN STANDARD

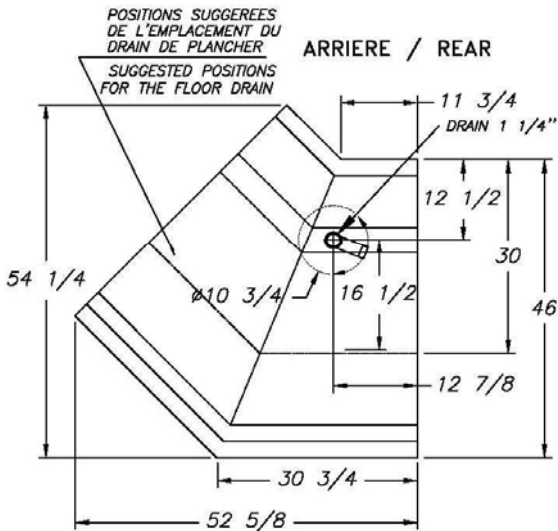

DEVANT-CIENT / FRONT-CUSTOMER

45° INTERIOR CORNER
45° COIN INTERIEUR
DRAIN STANDARD

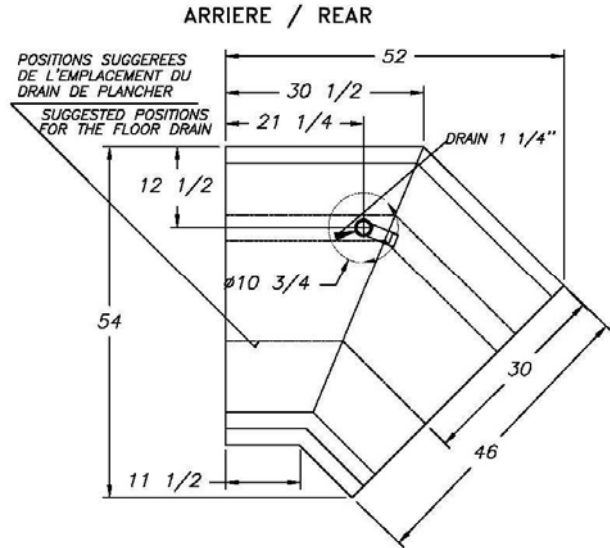

DEVANT-CIENT / FRONT-CUSTOMER



Section 1 – Meat/Viandes fraîches

M-13

Modèle EM6A Model

Multi-Deck Fresh Meat Merchandisers – Std Base
Présentoirs pour viandes fraîches à niveaux multiples – Base std

Refrigeration and Electrical Data / Données sur la réfrigération et l'électricité

Refrigeration Data			Defrost Data/Données de dégivrage						
Case Model	BTU/hr/ft*	Evaporator	# of	Hot Gas		Electric		Off Time	
		Temp.	Defrosts	Temp.	Failsafe	Temp.	Failsafe	Temp.	Failsafe
		(F)		Term.(F)	Time (min)	Term.(F)	Time (min)	Term.(F)	Time (min)
EMA	1550	20	3	50	20	50	40	nr	nr
Corner/Coin	BTU/hr/Case								
45° int.	4650	20	3	50	20	50	40	nr	nr
45° ext.	5820	20	3	50	20	50	40	nr	nr

Note: *BTU/hr/ft are for parallel operation. For sizing conventional/individual units multiply by 1.08.

Lighting Data/Données d'éclairage (120V)											
EMA		4 ft		6 ft		8 ft		10 ft		12 ft	
		Watts	Amps	Watts	Amps	Watts	Amps	Watts	Amps	Watts	Amps
Canopy											
	2 rows	64	0.53	100	0.83	128	1.06	164	1.36	192	1.6
	3 rows	96	0.78	150	1.25	192	1.59	246	2.05	288	2.4
Shelf Lighting/Eclairage tablettes											
	1 row	32	0.26	50	0.41	64	0.53	89	0.74	96	0.8
	2 rows	64	0.52	100	0.82	128	1.06	178	1.48	192	1.6
	3 rows	96	0.78	150	1.23	192	1.59	267	2.22	288	2.4
	4 rows	128	1.04	200	1.64	256	2.12	356	2.96	384	3.2
	5 rows	160	1.3	250	2.05	320	2.65	445	3.7	480	4

Electrical Data/Données électriques										
Case Model	Length	Fans/Ventilateurs			Éléments A/S heaters		Defrost heaters/Éléments de dégivrage			
		120 V			120 V		208 V		240 V	
		No of fans	Watts	Amps	Watts	Amps	Watts	Amps	Watts	Amps
EMA	4 ft	1	16	1	N/A	N/A	900	4.32	1200	5
	6 ft	2	32	2	---	---	1400	6.73	1860	7.75
	8 ft	3	48	3	---	---	1800	8.65	2400	10
	10 ft	3	48	3	---	---	2700	12.98	3600	15
	12 ft	4	64	4	---	---	2700	12.98	3600	15

Note : Ces présentoirs sont conçus pour une utilisation en magasin où la température et l'humidité n'excèdent pas 75°F et 55% H.R. La compagnie IFI est engagée dans une politique d'amélioration de ses produits. Les spécifications sont sujettes à changements sans préavis.

Note: These merchandisers are designed for use in stores where temperature and humidity do not exceed 75°F and 55% R.H. As continued product improvement is a policy of IFI, specifications are subject to change without notice.

